

4

3

2

1

REMOVABLE HOIST RING

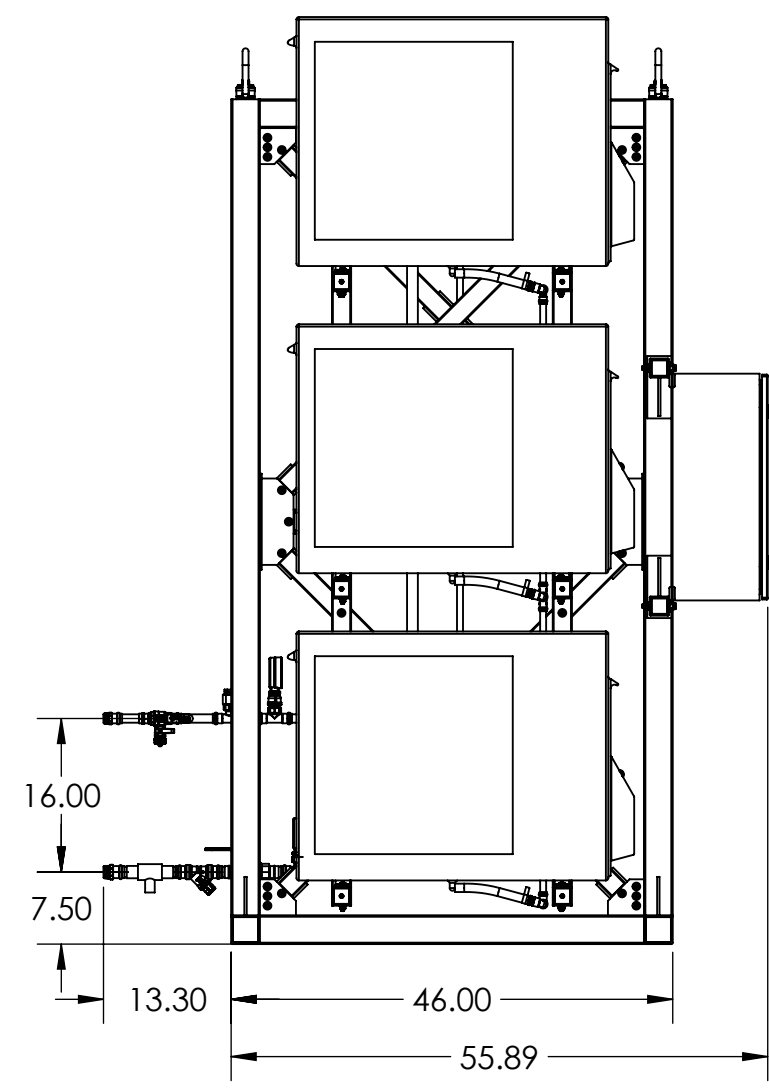
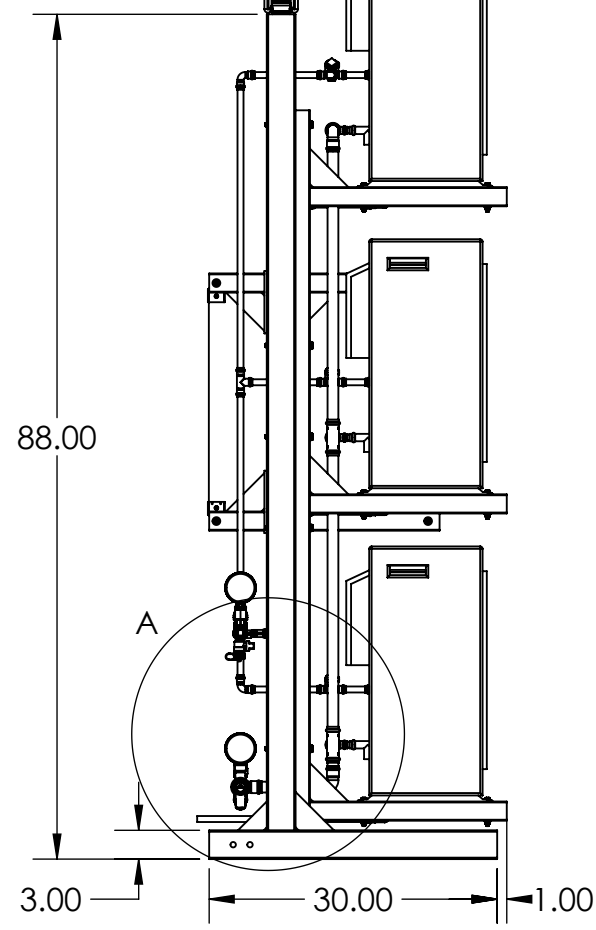

HOT WATER OUTLET  
3/4" MNPT

COLD WATER INLET  
1" MNPT

CONDENSATE DRAIN  
1/2" COPPER STUB

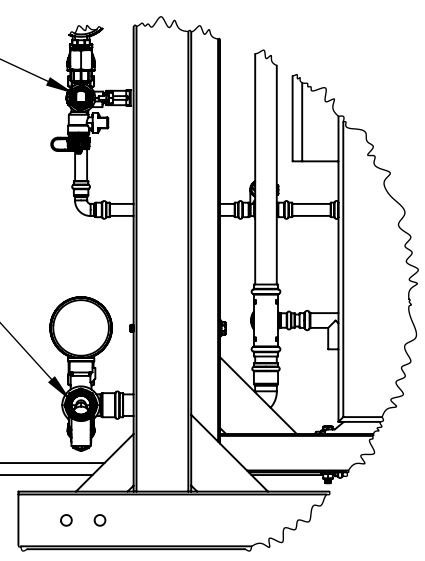

DETAIL A  
PIPING CONNECTIONS  
SCALE 1 : 10

NOTES:  
ALL DIMENSIONS IN INCHES  
**36" SERVICE CLEARANCE  
REQUIRED ON ALL SIDES**  
*SEE 003-00008 FOR  
RIGHT-HANDED VARIANT*

SMALL PLANET SUPPLY TUMWATER, WA		
TITLE: <b>DROPLET3-LH SUBMITTAL</b> (DIMENSIONS & CONNECTIONS)		
SIZE <b>B</b>	DWG. NO. <b>003-00045</b>	REV <b>A</b>
SCALE: 1:20		SHEET 1 OF 4

4

3

2

1

B

B

A

A

4

3

2

1

B

B

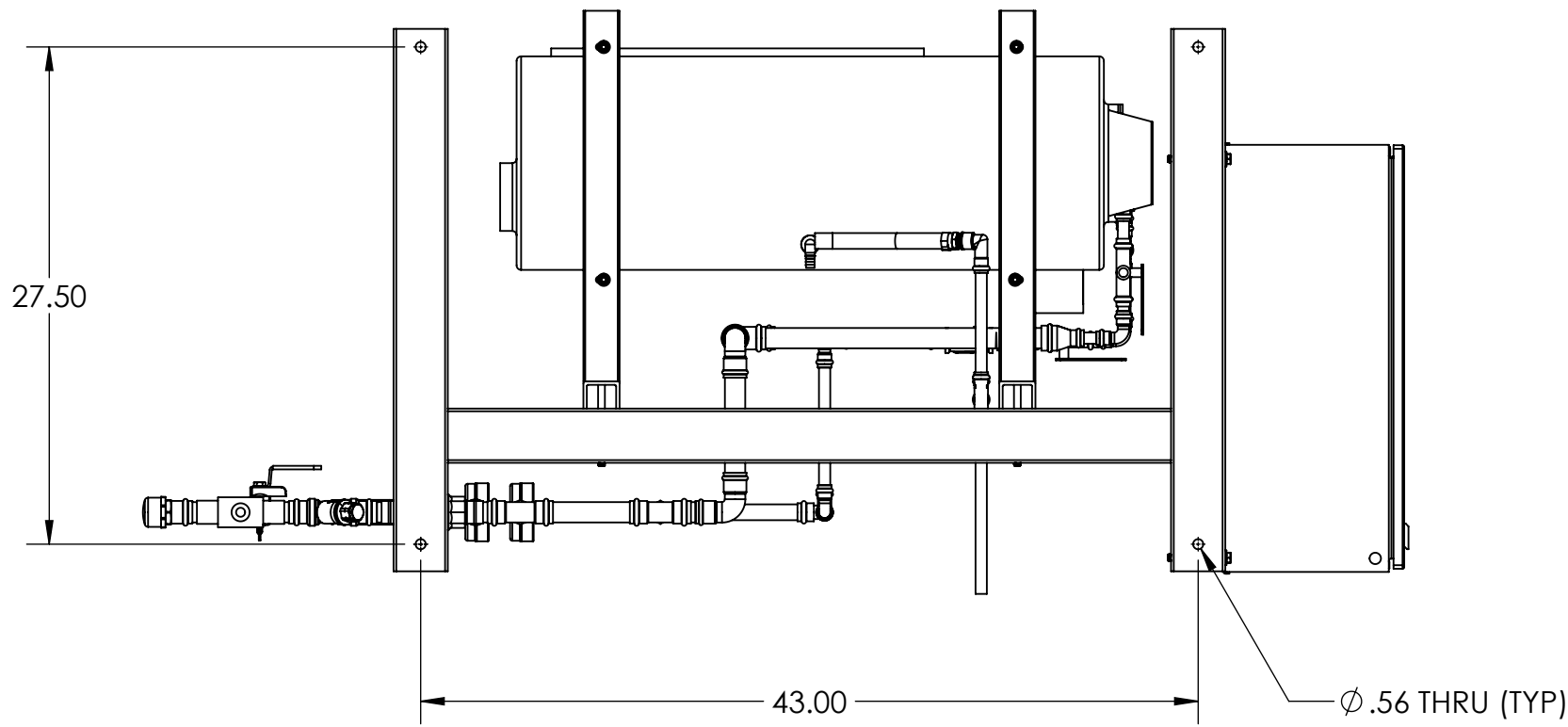

A

A

ALL DIMENSIONS IN INCHES		SMALL PLANET SUPPLY TUMWATER, WA	
<b>ANCHOR REQUIREMENTS:</b>		TITLE: <b>DROPLET3-LH SUBMITTAL</b> (MOUNTING REQUIREMENTS)	
(4) ANCHORS REQUIRED 1/2" DIAMETER 1,000 lbf UPLIFT CAPACITY PER ANCHOR 750 lbf SHEAR CAPACITY PER ANCHOR		SIZE <b>B</b>	DWG. NO. <b>003-00045</b>
		REV <b>A</b>	
SCALE: 1:10		⊕	SHEET 2 OF 4

4

3

2

1

4

3

2

1

PERFORMANCE

HEATING CAPACITY (ABOVE 5°F) [BTUH]	46,200
NOMINAL OUTPUT [GPM @ 100°F LIFT]	0.92
MAX. DAILY OUTPUT [GAL./DAY @ 100°F LIFT]	887
MAX. DAILY RUNTIME [HOURS / DAY]	16
AIRFLOW [CFM]	1,800
EXTERNAL STATIC PRESSURE [IN.-H <sub>2</sub> O]	0
SOUND LEVEL [dB(A)]	40
*MAX. PIPE LENGTH TO STORAGE TANKS [FT.]	55
*MAX. VERTICAL DISTANCE TO STORAGE TANK [FT.]	20
REFRIGERANT TYPE	R-744
TOTAL CHARGE [OZ.]	76.2
MAX. SYSTEM WATER PRESSURE [PSI]	75
HEAT TRACE CAPACITY [W/FT.] (OPTIONAL)	8

\*LIMITED BY HEAT PUMP INTERNAL CIRCULATOR PUMP AVAILABLE HEAD

ELECTRICAL

VOLTAGE/PHASE/FREQ.	208V/1Ø/60Hz
FLA [A]	37.7
MCA [A]	54.4
MOCP [A]	60

WEIGHT

DRY WEIGHT, INSTALLED* [LBS.]	850
-------------------------------	-----

\*APPROX.

COMPONENT & CONSTRUCTION DETAIL

20-MESH WYE-STRAINER LOCATED ON COLD SUPPLY
INDIVIDUAL HEAT PUMP ISOLATION AND CHECK VALVES
HEAT TRACE ON PIPING AND CONDENSATE DRAIN PANS (OPTIONAL)
POWDER-COATED STEEL FRAME
1-1/2" PIPE INSULATION
TYPE K COPPER PIPING
ONBOARD STAGING CONTROLLER
UL508A PANEL

MOUNTING ANCHORS

DIAMETER	1/2"
UPLIFT/PULLOUT CAPACITY [lbf]	1,000
SHEAR CAPACITY [lbf]	750
NO. OF ANCHORS REQUIRED	4

FIELD CONNECTIONS

<u>ELECTRICAL</u>	LINE	
	NEUTRAL	
	GROUND	
<u>PLUMBING</u>	HOT WATER OUTLET	3/4" MNPT
	COLD WATER SUPPLY	1" MNPT
	CONDENSATE DRAINS	1/2" COPPER STUB

SMALL PLANET SUPPLY  
TUMWATER, WATITLE:  
**DROPLET3-LH  
SUBMITTAL**  
(TECHNICAL DATASHEET)

SIZE	DWG. NO.	REV
<b>B</b>	<b>003-00045</b>	<b>A</b>
SCALE: NTS		SHEET 3 OF 4

4

3

2

1

B

A

4

3

2

1

B

B

A

A

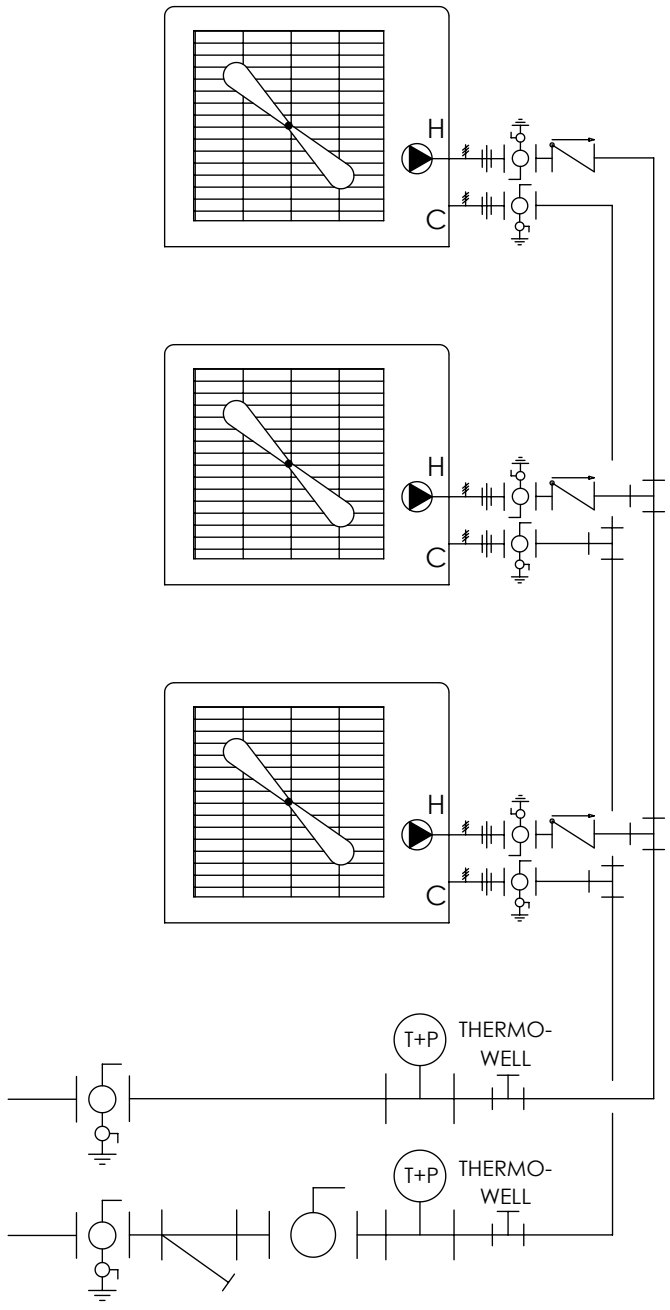

SMALL PLANET SUPPLY TUMWATER, WA		
TITLE: <b>DROPLET3-LH SUBMITTAL (PIPING DIAGRAM)</b>		
SIZE <b>B</b>	DWG. NO. <b>003-00045</b>	REV <b>A</b>
SCALE: NTS		SHEET 4 OF 4

4

3

2

1