

4

3

2

1

B

B

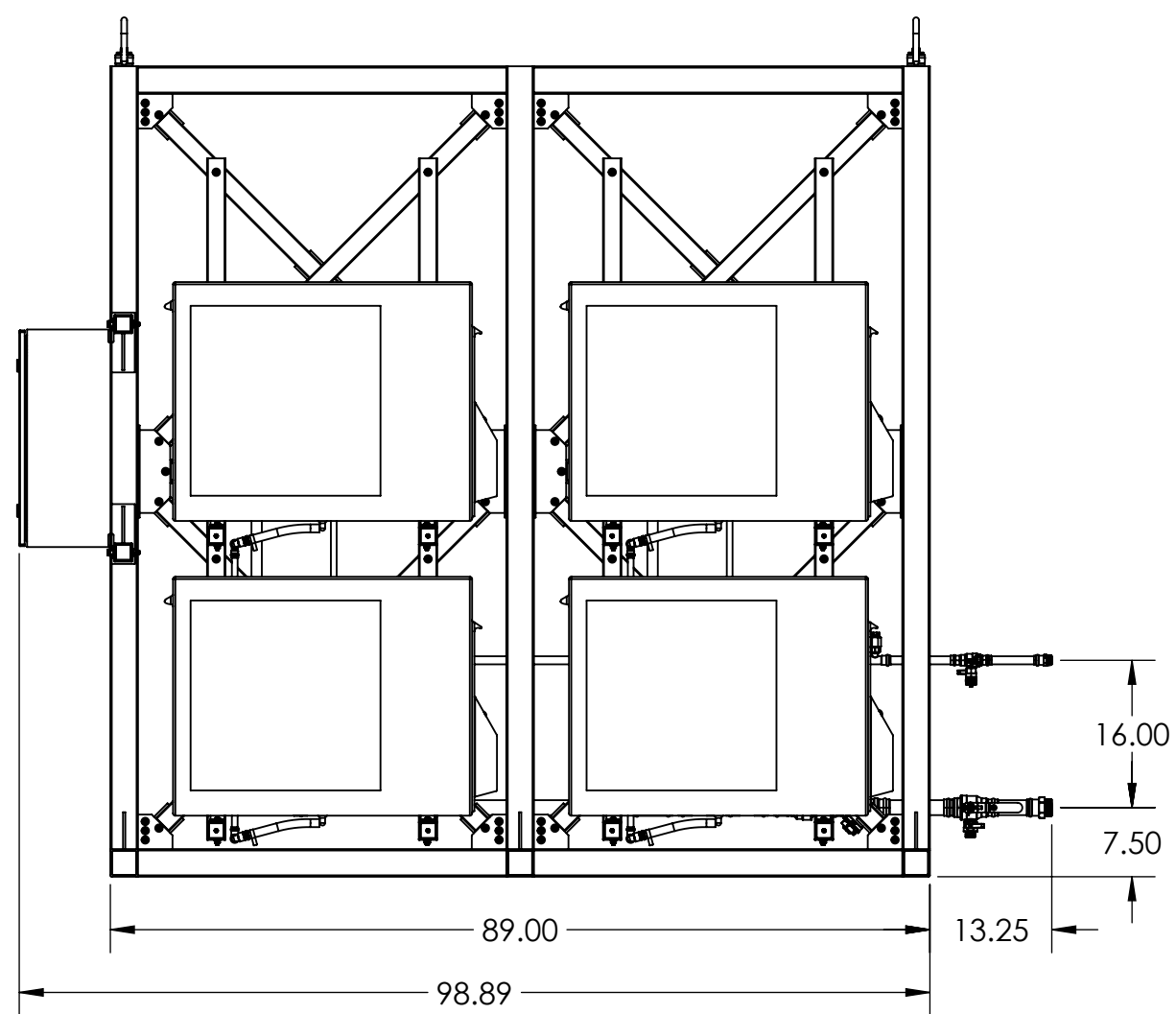

REMOVABLE HOIST RING

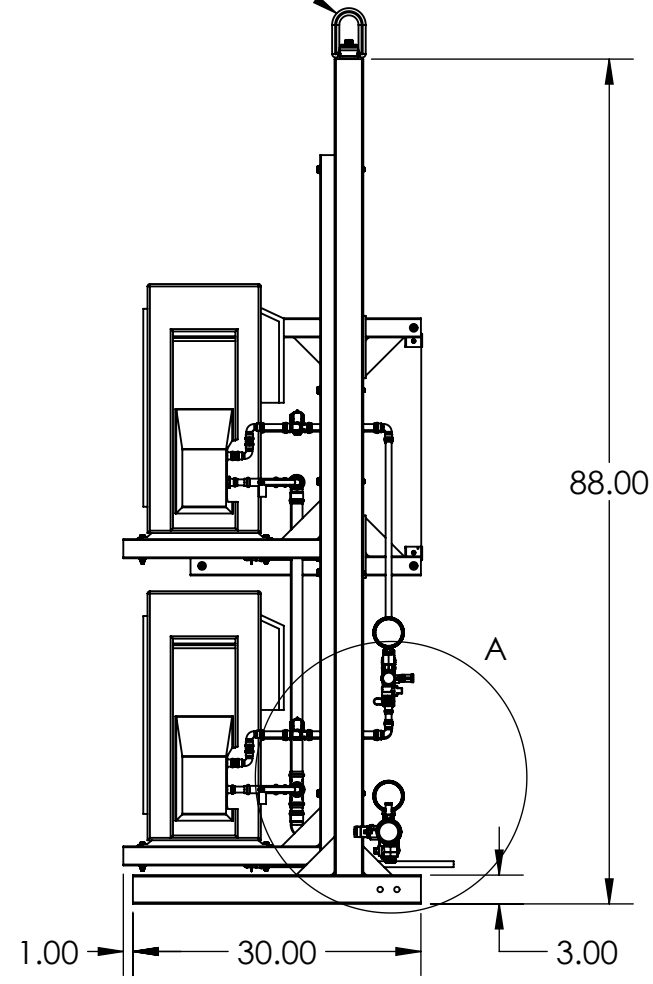

A

A

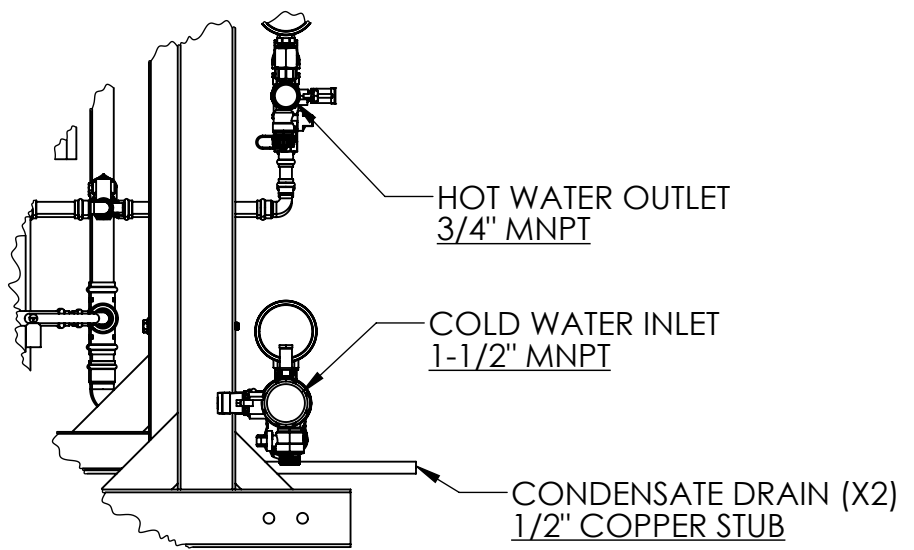

DETAIL A
PIPING CONNECTIONS
SCALE 1 : 10

NOTES: ALL DIMENSIONS IN INCHES 36" SERVICE CLEARANCE REQUIRED ON ALL SIDES <i>SEE 003-00046 FOR LEFT-HANDED VARIANT</i>	SMALL PLANET SUPPLY TUMWATER, WA TITLE:		
	DROPLET4-RH SUBMITTAL (DIMENSIONS & CONNECTIONS)		
	SIZE B	DWG. NO. 003-00009	REV C
	SCALE: 1:20		SHEET 1 OF 4

4

3

2

1

4

3

2

1

B

B

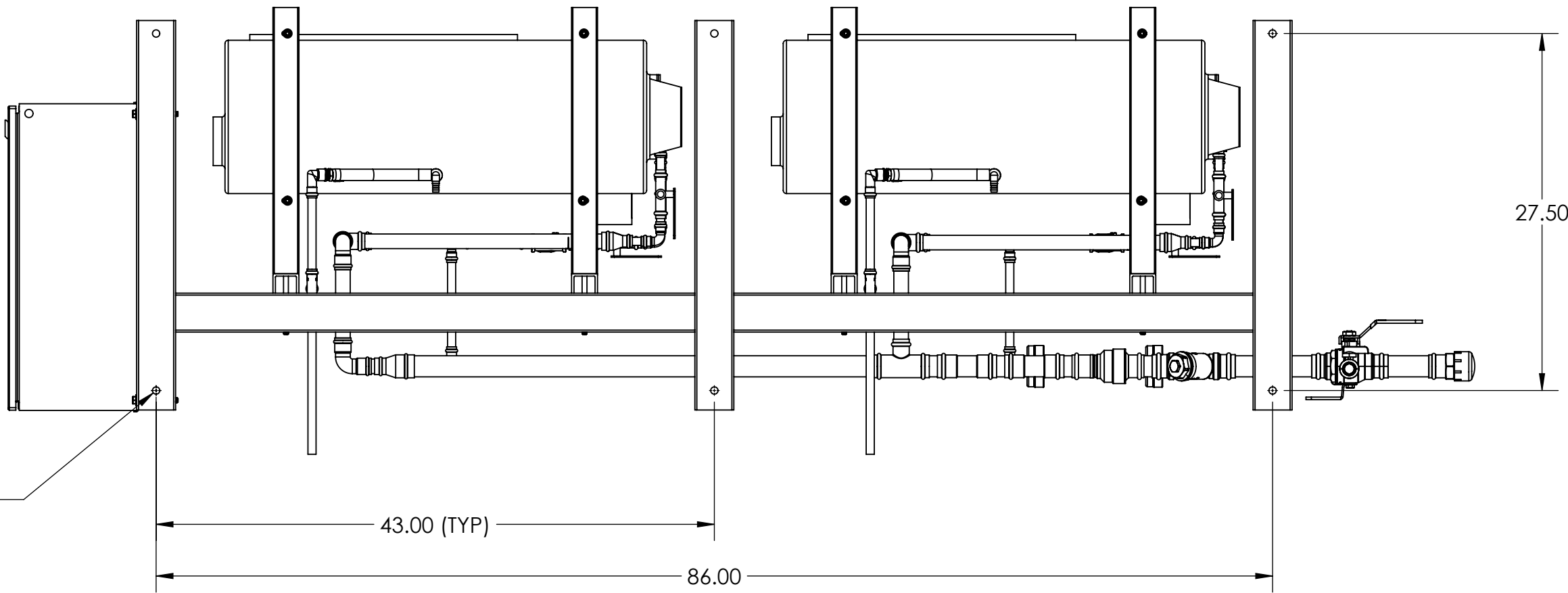

$\phi .56$ THRU (TYP)

43.00 (TYP)

86.00

27.50

A

A

4

3

2

1

ALL DIMENSIONS IN INCHES		SMALL PLANET SUPPLY TUMWATER, WA	
ANCHOR REQUIREMENTS:		TITLE: DROPLET4-RH SUBMITTAL (MOUNTING REQUIREMENTS)	
(6) ANCHORS REQUIRED 1/2" DIAMETER 1,000 lbf UPLIFT CAPACITY PER ANCHOR 750 lbf SHEAR CAPACITY PER ANCHOR		SIZE B	DWG. NO. 003-00009
		SCALE: 1:10	REV C
		SHEET 2 OF 4	

4

3

2

1

PERFORMANCE

HEATING CAPACITY (ABOVE 5°F) [BTUH]	61,600
NOMINAL OUTPUT [GPM @ 100°F LIFT]	1.2
MAX. DAILY OUTPUT [GAL./DAY @ 100°F LIFT]	1,183
MAX. DAILY RUNTIME [HOURS / DAY]	16
AIRFLOW [CFM]	2,400
EXTERNAL STATIC PRESSURE [IN.-H ₂ O]	0
SOUND LEVEL [dB(A)]	40
*MAX. PIPE LENGTH TO STORAGE TANKS [FT.]	55
*MAX. VERTICAL DISTANCE TO STORAGE TANK [FT.]	20
REFRIGERANT TYPE	R-744
TOTAL CHARGE [OZ.]	101.6
MAX. SYSTEM WATER PRESSURE [PSI]	75
HEAT TRACE CAPACITY [W/FT.] (OPTIONAL)	8

*LIMITED BY HEAT PUMP INTERNAL CIRCULATOR PUMP AVAILABLE HEAD

ELECTRICAL

VOLTAGE/PHASE/FREQ.	208V/1Ø/60Hz
FLA [A]	44.7
MCA [A]	55.8
MOCP [A]	60

WEIGHT

DRY WEIGHT, INSTALLED* [LBS.]	1,350
-------------------------------	-------

*APPROX.

COMPONENT & CONSTRUCTION DETAIL

20-MESH WYE-STRAINER LOCATED ON COLD SUPPLY
INDIVIDUAL HEAT PUMP ISOLATION AND CHECK VALVES
HEAT TRACE ON PIPING AND CONDENSATE DRAIN PANS (OPTIONAL)
POWDER-COATED STEEL FRAME
1-1/2" PIPE INSULATION
TYPE K COPPER PIPING
ONBOARD STAGING CONTROLLER
UL508A PANEL

MOUNTING ANCHORS

DIAMETER	1/2"
UPLIFT/PULLOUT CAPACITY [lbf]	1,000
SHEAR CAPACITY [lbf]	750
NO. OF ANCHORS REQUIRED	6

FIELD CONNECTIONS

<u>ELECTRICAL</u>	LINE	
	NEUTRAL	
	GROUND	
<u>PLUMBING</u>	HOT WATER OUTLET	3/4" MNPT
	COLD WATER SUPPLY	1-1/2" MNPT
	CONDENSATE DRAINS	(2) 1/2" COPPER STUB

SMALL PLANET SUPPLY
TUMWATER, WATITLE:
**DROPLET4-RH
SUBMITTAL**
(TECHNICAL DATASHEET)

SIZE	DWG. NO.	REV
B	003-00009	C
SCALE: NTS		SHEET 3 OF 4

4

3

2

1

B

A

B

A

4

3

2

1

B

B

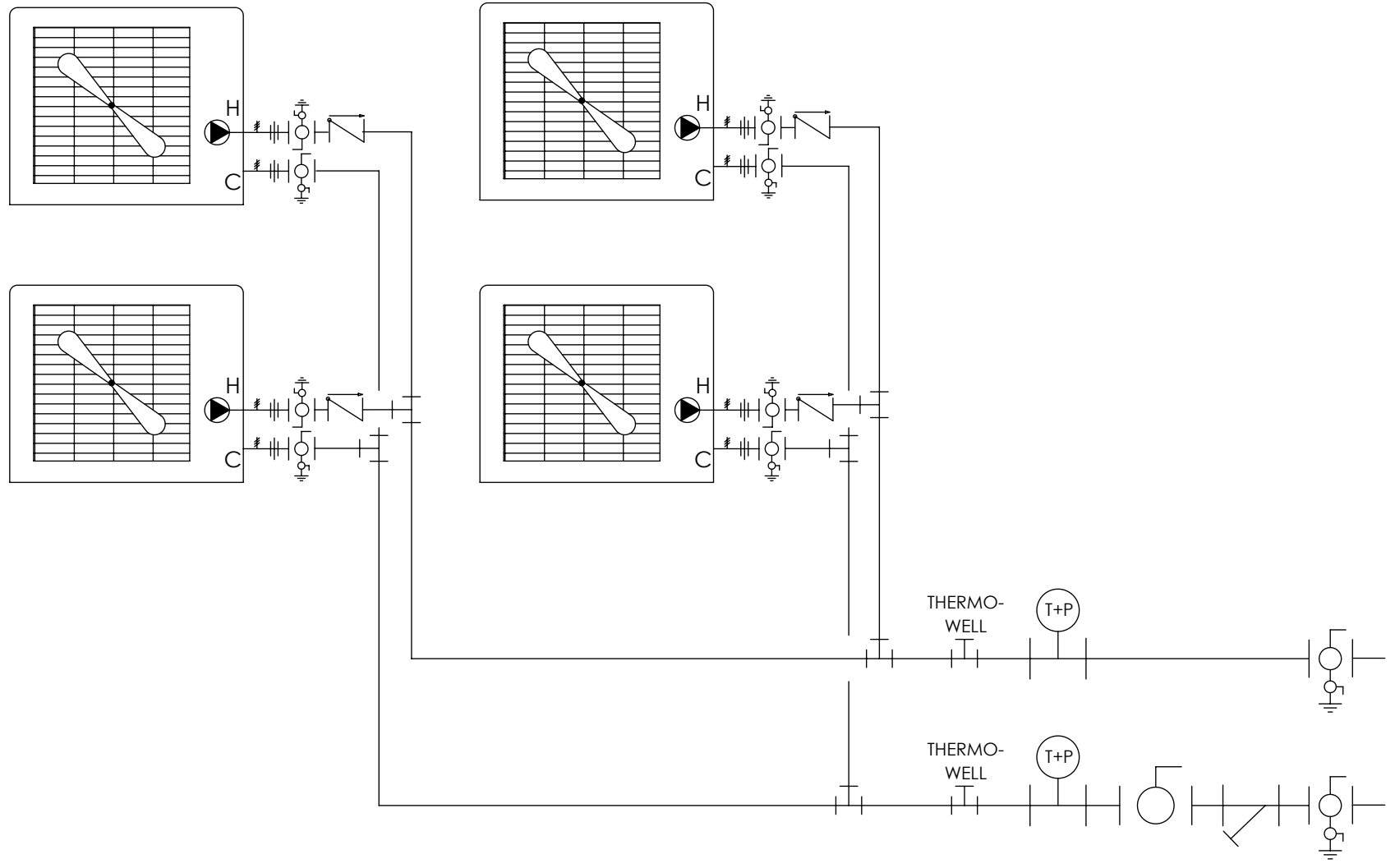

A

A

4

3

2

1

SMALL PLANET SUPPLY TUMWATER, WA		
TITLE: DROPLET4-RH SUBMITTAL (PIPING DIAGRAM)		
SIZE B	DWG. NO. 003-00009	REV C
SCALE: NTS		SHEET 4 OF 4